

**FRANKE**









# COLLECTIONS

2026 · 2027

## Sinks









The sinks in the pictures do not have mixer holes. The exact position can be seen from the technical drawing next to the picture.

 POP-UP SINK WASTE Removable remote control for opening and closing the drain. Check for the presence of a second hole.	 COMPLETE WITH ACCESSORIES Product supplied with accessories included. Optional	 WASTE DISPOSER For easier disposal of wet waste. (installation permitted subject to municipal regulations). Optional
 FLUSHMOUNT	 UNDERMOUNT	 STANDARD
		 SLIM











## Taps

 MULTIFUNCTIONAL TAPS all-in-one home solution that allows you to easily choose filtered, sparkling, chilled and instant boiling water	 FILTERED WATER No need to buy bottled water and you can do your bit for the environment.	 TAP WILL WORK WITH LOW PRESSURE SYSTEMS Delivering at least 4 litres per minute of hot water at 0.3 bar pressure.
 TOUCH FREE	 PULL OUT NOZZLE	 PULL OUT SPRAY
		 SWIVEL SPOUT



























## Gas Hobs

 DUAL TRIPLE CROWN Thanks to the two concentric crowns, it is possible to select various degrees of flame intensity in accordance with cooking requirements.	 INTEGRATED ELECTRONIC IGNITION Gas ignition device integrated into the knob. Enables gas to be lit with no need for additional flames.	 CAST IRON GRILLES Solid and non-deformable cast iron grilles ensure a stable, robust support surface, as well as lending the hob an elegant, professional appearance. Optional
 DUAL CROWN The flame is distributed across the two crowns, for rapid, even cooking.	 SAFETY VALVE An essential device that cuts off the gas flow in the event that the flame is accidentally extinguished.	 KNOBS Available in various finishes, the worktop knobs can be matched to the ovens, for a perfectly coordinated look. Optional
 CAST IRON GRILLES Solid and non-deformable cast iron grilles ensure a stable, robust support surface, as well as lending the hob an elegant, professional appearance.	 LOWERED COOKING SURFACE The cooker top and burners are recessed into the kitchen worktop, for the flattest possible surface.	













## Induction hobs

 BRIDGE This function enables you to use two induction zones separately or link them together when you're cooking for a crowd. For example you can create an internal 'bridge' that joins the front left cooking zone to the rear left zone.	 KEEP WARM This function keeps food hot after cooking so it can be served at the perfect temperature, and enables liquids to evaporate slowly.	 MELTING This function brings food to an ideal melting temperature without risk of burning.
 FLEXI ZONE This function enables two cooking zones to be combined form 1 large cooking zone and used at the same level of power.	 BOILING This function brings water to the boil and keeps it at this temperature with less energy consumption.	 GRILLING Designed for grilling food according to thickness. When the ideal temperature for adding the food is reached, the hob emits an acoustic signal. The hob then stabilises the desired temperature, keeping it constant.
 COOKASSIST/SPECIAL FUNCTIONS With this function, the pre-set cooking modes can be activated, enabling the ideal power level to be selected, for perfect results every time.	 SIMMERING This function maintains a low temperature, enabling food to be cooked for long periods with no risk of burning. Ideal for long cooking times.	 MOKA A function designed for use with a moka coffee pot.
		 PAN FRYING Function for preheating an empty pan, or a pan containing seasoning.







## Ovens

 STATIC COOKING For cooking any type of dish on a single shelf. It is preferable to use the shelf on the second level.	 COOKASSIST This function enables all food types to be cooked fully automatically.	 STEAM COOKING This function enables food to be cooked exclusively using steam - for preparing tasty, healthy dishes.
 BOTTOM COOKING For browning the bottom of your dishes. This function is also recommended for slow cooking, for finishing steaks and for making thick, concentrated sauces.	 AUTO BREAD This function automatically selects the best baking method and ideal temperature for all bread types.	 THERMOVENTILATED COOKING + STEAM This function enables combined steam cooking, for dishes that are golden and crispy on the outside and soft on the inside.
 VENTILATED COOKING For baking cakes and desserts with a liquid filling on a single shelf. This function can also be used for cooking on two shelves. Invert the position of the dishes you are cooking, for more even results.	 BREAD For baking breads of different types and sizes. It is preferable to use the shelf on the second level.	 MULTICOOKING This function allows up to 4 different dishes to be cooked at the same time without mixing flavours.
 ECO THERMOVENTILATED COOKING For cooking roasts with stuffing and cuts of meat on a single shelf. This function intermittently activates the fan at a low speed, preventing food from drying out. With this ECO function, the light remains off during cooking.	 AUTO DESSERT This function automatically selects the best baking temperature and mode for any type of dessert (biscuits, sponge cakes, tarts, etc.).	 PIZZA COUNTRY This cooking mode delivers the most heat in the lower part of the oven, whilst simultaneously delivering heat above, imitating the heat distribution of a wood-fired oven.
 THERMOVENTILATED COOKING For simultaneously cooking different foods which need the same cooking temperature on several shelves (max. three). This function enables dishes to be cooked at the same time without the flavours or odours leaching from one food to another.	 PROVING For optimal leavening of sweet or savoury doughs and mixtures.	 QUICK COOKING The most powerful function. It can be used ahead of any type of cooking in order to rapidly reach the selected temperature, before proceeding with the desired cooking function.
 GRILL For grilling chops, skewers and sausages, cooking vegetables au gratin or giving bread a golden crust. When grilling meat, it is advisable to use a drip pan to collect the cooking juices: place it one level below the grill and add 200 ml of water.	 DEFROSTING To speed up food defrosting.	 TOP COOKING (for gas ovens) This function can be used for putting the "finishing touches" on cooking. Also ideal for baking and browning.
 TURBO GRILL For roasting large pieces of meat (leg joints, roast beef, whole chickens). It is advisable to use a drip pan to collect the cooking juices: place it one level below the grill and add 500 ml of water.	 PREHEATING For rapidly preheating the oven.	 BOTTOM COOKING (for gas ovens).
 MAXI COOKING For cooking particularly large cuts of meat (over 2.5 kg).	 PYROLYTIC CLEANING Eliminates cooking residues by means of a very high temperature cycle.	 SPIT ROAST (for gas ovens) The ideal function for rotisserie cooking (whole).
 PIZZA This function automatically selects the best baking temperature and mode for any type of pizza.	 STEAM CLEANING The action of the steam that is released during this special low-temperature cleaning cycle enables dirt and food residues to be removed with ease. Pour 200 ml of drinking water into the bottom of the oven and activate the function for 35 minutes at 90°C. Activate the function when the oven is cold, and leave to cool for 15 minutes at the end.	 GRILL WITH SPIT ROAST For immediate browning of the surface of food, ensuring it remains tender inside.

## Microwave

 MICROWAVE For fast cooking and heating of food or beverages.	 COMBINATON GRILL Cook and grill food quickly by combining the microwave and grill.	 AUTO THERMOVENTILATED COOKING For rapid oven cooking and optimal results. Use pans that are oven and microwave safe.
 MICROWAVE For fast cooking and heating of food or beverages.	 TURBO GRILL For perfect results, combining the action of a grill and a fan oven.	 AUTOMATIC DEFROST For rapid defrosting of different food types - simply select the weight.
 COMBINED THERMOVENTILATED COOKING For preparing oven-cooked dishes fast.	 COMBINED TURBO GRILL For cooking and browning food quickly, combining the functions of a microwave, grill and fan oven.	 AUTOMATIC REHEATING For reheating ready-to-eat food, both frozen and at room temperature.
 GRILL For browning, grilling or cooking dishes au gratin.	 PREHEATING For rapidly heating the oven before a cooking cycle.	 STEAM COOKING For steaming food such as vegetables or fish, using the steamer provided.

## Hoods

DIGITAL DISPLAY 	TIMER 	ANTI CONDENSATION 	REMOTE CONTROL 	REMOTE CONTROL OPTIONAL 	CONTINUOUS VENTILATION 24 h 	SPEED NUMBER + INTENSIVE 	FILTER FUNCTION 	K-LINK TECHNOLOGY 
						3 ≡ 3 ± 4 ±		

# A Great Performance Deserves a Great Stage

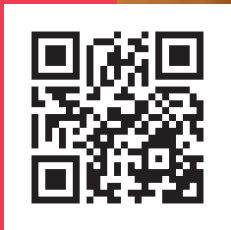

Scan to see our  
brand campaign.

THE SHOW IS HOME

**FRANKE**

# COLLECTIONS

## 2026 · 2027

### FAMILIES

Mythos  
Maris  
Smart

### PRODUCT CATEGORIES

#### Sinks & Bowls

- 26 Stainless Steel
- 35 Fraganite

#### Taps

- 38 Taps

#### Hoods

- 44 Hob Extractors
- 48 Hoods
- 54 Downdraft

#### Appliances

- 56 Ovens
- 60 Microwaves
- 64 Induction Hobs
- 68 Dishwashers
- 70 Refrigerator
- 72 Wine Cooler
- 74 Coffee Machine

- 76 Food Waste Disposer

- 78 Clean & Care





[www.franke.com](http://www.franke.com)



[facebook.com/FrankeHomeSolutions](https://facebook.com/FrankeHomeSolutions)



[instagram.com/franke\\_group](https://instagram.com/franke_group)



[x.com/franke\\_group](https://x.com/franke_group)



<http://www.youtube.com/@FrankeHomeSolutions>



[pinterest.es/FrankeGroup](https://pinterest.es/FrankeGroup)



Scan to view  
the NEW online  
brand campaign.



# Years of experience, yet still as curious as kids.

At Franke, we have been looking for new solutions and innovations for over 100 years and our attitude still has not changed. In 1911 we combined traditional craftsmanship, precision engineering and a constant pursuit of innovation, three principles that remain at our core.

## A story forged in Swiss precision

Our story began at the beginning of the last century as a small sheet-metal business in Rorschach, Switzerland, established by Hermann Franke.

Since then, we opened up to the world and inaugurated manufacturing facilities all around the globe that led us to become leaders in the kitchen sinks segment, and home solutions altogether.



# The recipe for a healthier future

We're on a mission to help create a more sustainable planet, one innovation at a time. From designs built with the use of sustainable materials, to efficiency optimization and waste reduction, we act responsibly throughout our business and beyond for positive long-term impact.



## Taking care of the environment

Our vision is to reach net-zero greenhouse gas (GHG) emissions across our value chain by 2050 from a 2020 base year.

We have established clear goals that support this ambition to contribute to a more sustainable world for our customers, employees, and society.

We developed our near-term and net-zero targets in 2023 in line with the Paris Climate Agreement, and they were validated by the Science Based Targets initiative (SBTi) in February 2024, setting a cornerstone in our sustainability journey.

## Resources

In 2023, we continued the switch from Styrofoam packaging to cardboard for the Franke range of Fraganite and Tectonite material sinks across Franke's distribution centers around the world.

Franke's total share of renewable packaging was 89.9 percent in 2023.

## Waste

75% of waste across Franke Group was recycled.

## Packaging

Franke has switched from Styrofoam to cardboard packaging for its range of granite and tectonite sinks.

91% of Franke packaging is made from renewable materials.

## Creating a proactive safety-first culture

People are at the core of what we do, and their safety needs to be a pre-condition of how we work. This approach is enshrined in our company values and drives our safety and occupational health measures. We view the prevention of physical and mental harm and the promotion of workers' health and wellbeing as a key responsibility in recognition of the fundamental human rights of workers.

**“ We've reduced our scope 1 and 2 emissions for eight years running and our net-zero emissions reduction targets have been validated by the SBTi. ”**

Patrik Wohlhauser, Franke CEO

## Innovation for sustainable living

Our eco-friendly innovations are designed to empower cleaner living at home and inspire everyday wellbeing.

### Taps

Stainless steel models are made of 100% recyclable steel. Our multifunctional taps range, including the Mythos Water Hub and the Vital taps with their dedicated filtration systems, reduce need for bottled water. The Atlas Neo Sensor reduces water waste by up to 50%



### Sinks

Franke's sinks ranges are exemplary in terms of usage of sustainable materials such as stainless steel, Fraganite and ceramic that guarantee extraordinary product durability, resistance and long-lasting quality.

### Hoods

All models are designed to reduce energy consumption and improve energy use with AUTO Functions made to automatically save energy. Class A++ hoods reduce energy consumption up to 85%. Long lasting filters and activated carbon ceramic filters can be regenerated and are designed to further reduce waste compared to standard disposable carbon filters.



### Hob extractors

Our extractor hobs offer maximum energy efficiency. For example, the extremely powerful Mythos 2gether extractor hob is classed in the best possible energy efficiency rating A+++ thanks to its brushless motor.

### Ovens and microwaves

With A and A+ energy ratings offering multi functions that enable different foods to be cooked in one cycle, and a steam cleaning function that allows cleaning without the need of using harmful chemicals.



### Refrigerators

Designed with cold zone compartments to ensure food stays fresher for longer, No Frost technology to help prevent defrosting, and Vacation mode which allows you to keep the freezer compartment active when the fridge isn't.

# Experience our new Showroom

Welcome to the Franke's Aarburg Showroom a place of discovery.

It has been key to bring Franke's new positioning to life in the Aarburg showroom concept, as well as in all spaces applying and adapting the new brand styleguide. The new colors from primary to a wide modern secondary colors selection has been applied to the display creating a vibrant, fresh and contemporary design combination.

The highlights are our product families Mythos, Maris and Maris representing in the best way Franke as System Provider. Within the showroom there is also an attention to people and their well-being with open and clear understandable demonstration corners in a delightful natural material surrounding.

Franke's innovations are brought into the showroom with a superior quality look, tone and feel, elevating to the fullest the brand and products experience.

## Aarburg Showroom

Franke-Strasse 2  
4663 Aarburg  
Switzerland  
Phone: +41 62 787 31 31  
Fax: +41 62 787 30 18



Scan  
to view  
the Aarburg  
showroom





**FRANKE**

**A GREAT  
PERFORMANCE  
DESERVES A  
GREAT STAGE**

Franke Home Solutions

**WELCOME**  
willkommen



**FRANKE**

**HOME**

**SOLUTIONS**

## Solutions that work together

Our kitchens are places to live: we cook there, eat there, spend time together there, more often than not all at the same time. We thoroughly observed the movements we make in our kitchens and developed proper home solutions rather than simple appliances.

Our single products all merge together in functional systems aimed to facilitate your life and please your eye thanks to perfectly matching colours, designs and combinations.

When everything comes together, it is easier to enjoy every moment.

### Food preparation areas

**Taps, sinks and waste management systems.**

Award-winning, smart, eco-friendly taps perfectly completed by elegant, spacious bowls that can be equipped with accessories or other smart tools so you have everything you need, always at hand. Everything in the best, most durable and hygienic materials, for example stainless steel or our exclusive Fraganite.



### Hoods

**Wall, ceiling, built-in, island hoods.**

Every kitchen has specific needs, so we created a range of hoods able to surprise you with technology, efficiency, lighting and beautiful designs. Discover the available colours, shapes and special technologies from built-in screens to air-purifying systems.

### Appliances

**Ovens, microwaves, hobs, refrigerators and dishwashers.**

When we design our appliances, we do so with your routines in mind, so that we can offer functional solutions that are easy to use, smart in their features and beautiful to look at.



# Inspir

There is no place like home. And there are no two homes alike. The way we cherish our own nest is just as unique as we are, each one with different tastes, preferences, and needs. To help you get inspired and create the kitchen environment of your dreams, and enjoy it every day, we developed three different **families** of products.

## Mythos

### A passion for the best

Our most premium range. Technology meets design, while even the smallest details are carefully sought-after. This family sets its goal to the highest levels, combining the very essence of functionality with that of beauty.

## Maris

### Family in the kitchen

A family inspired by families. Cosy and functional, for savouring the heartwarming experience of a family get-together. Maris' philosophy is simple: welcome anyone, anytime with the pride and joy of a homemade dinner.

## Smart

### Straight to what matters

The simplest things work the best. Essential in its perfection, to jump to what matters the most: bringing joy to your kitchen. A family created to fulfill any need and preference.

What will your kitchen look like it's up to you,  
but whatever your way of bringing joy home, you can count on us.

# ations







**Bowl:** Mythos Masterpiece - BXM 110-68 **Tap:** Mythos Masterpiece  
**Soap Dispenser:** Atlas

# Mythos



**Hob Extractor:** Mythos 2gether Icon Steel FMY 8391R



**Oven:** Mythos - FMY 99 P XS **Coffee Machine:** Mythos - FMY 45 CM XS  
**Wine Cooler:** Mythos - FMY 24 WCR XS **Warming Drawer:** Mythos - FMY 14 DRW XS



**Bowl:** Maris Black Collection - MRG 610-72 TL **Tap:** Active - Pull Out Spray  
**Soap Dispenser:** Active

# Maris



**Extractor Hob:** Maris 2gether - FMA 839 HI



**Oven:** Maris - FMA 97 P XS

**Microwave:** Maris - FMA 45 MW XS









**Sink:** Sirius 2.0 - S2D 611  
**Tap:** Lina - Swivel Spout

# Smart



**Hood:** Smart Deco - FSMD 508 YL **Hob:** Smart - FSM 804 | B BK  
**Oven:** Smart - FSM 97 P XS **Microwave:** Smart - FSM 45 MW XS

# Show what you're made of!

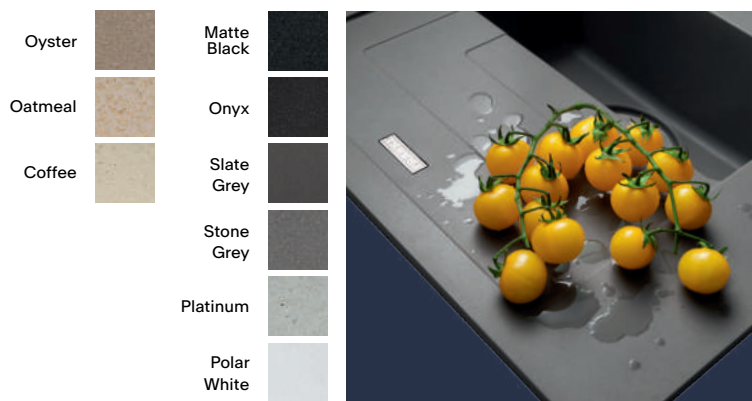

## Fragranite

An exceptionally tough material, highly resistant to burns, dents, chips and stains. Pioneered by Franke, it's a unique material with a subtle sheen that is warm to the touch thanks to its close to 80% of quartz sand. The surface is finely textured ensuring high hygiene standards.

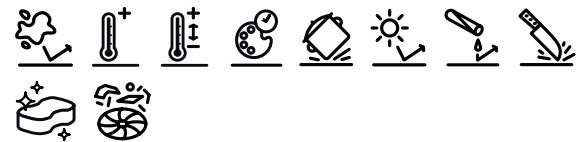

## Fraceram

Ceramic sinks have a smooth, impervious surface, which stands up to heat, staining, impacts and resist to all standard household chemicals with ease. Ceramic sinks have been a popular choice for years and create a classic combination with a variety of work surfaces such as wood, glass and granite.

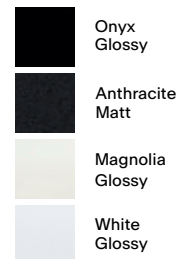

## F-Inox Technology

An exclusive Franke coating able to group water molecules and allowing you to dry your sink without ring stains. Water repellent and scratch-resistant, this futuristic coating also fears no heat up to 100°. A real and long-lasting beauty formula that you can appreciate from our Masterpiece family.



Shiny or Matt; smooth or stone-like, extra-strong or super trendy. Your kitchen can speak volumes about you, so every detail counts. To offer you the chance to create your very own perfect kitchen, our range of materials is designed to please any taste, match any style and resist any endeavor. Discover each material's precision-engineered character and unique benefits to choose the one that suits your needs the best and you like the most.



## Stainless Steel

Whether you prefer the more reflective qualities of the polished finish or the more subtle look of the silk or brushed finishes, which give a more matt sheen, there is a Stainless Steel solution for you. Any Franke Stainless Steel product is made from premium quality chrome nickel steel, which looks stunning and is highly resistant to staining, rust and corrosion - plus it won't chip, craze, flake, or break. If Stainless Steel is one of the most popular materials in the kitchen, it's for good reason.



## PVD Coating

PVD, standing for 'Physical Vapor Deposition', is a coating technology that makes Stainless Steel tapware even more resistant to abrasions, scratches and corrosion and offers exceptional aesthetic features as well. A tap treated with a PDV coating even resists UV rays and makes fingerprints less visible in a busy kitchen. There are now an array of other stunning finishes to choose from: Industrial Black, Anthracite, Copper and Gold, you really can find something to suit every style of kitchen.

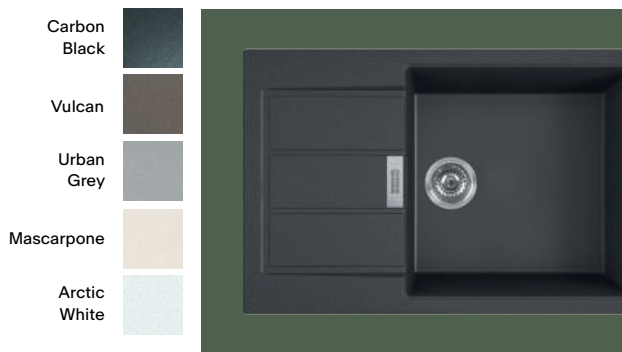

## Tectonite

Heat, shock and impact don't scare our Tectonite. Sturdiness combined with unique design freedom makes Tectonite sinks the ultimate choice for hardworking, stylish kitchens. New technology represents a giant leap forward for synthetic materials, whilst allowing for exciting minimalist designs in a new plethora of trendy colours.







# It's always been in our heritage to meet your **needs.**

## **Beautiful and made for real-life use. Steel represents our kitchen ideal.**

The sheer quality of Franke products can be seen and felt. We use AISI 304 18/10 steel, which is produced in Italy and Europe: a choice that reflects our dedication to quality, one of our core priorities over the 100-plus years of our history.

Strong and robust, it maintains its brilliance over time, making it the defining feature of the living spaces in which it is installed.

Its superb technical features ensure that it is always in demand, and highly appreciated by professionals in the haute cuisine sector: furthermore, stainless steel is an extremely hygienic material, and is easy to clean and recyclable. Aesthetically pleasing and functional to use: stainless steel really represents quality in shining armour.

## **Customer Care and Technical Assistance**

To report any problems of the product, please contact Customer Service.

The first on the line to help you will be our Authorised Service Partner, providing you with advice and instruction to solve the issue. If unsuccessful, we will proceed by sending you directly the easy-fix parts you will need or the Authorised Service Partner will be available to solve any technical issue and restore the conformity of the product through a repair or a replacement. Do not worry, we are here to help and your satisfaction comes first.

The Customer Service number 1900.225.950

For more information  
and for details on warranty  
conditions: [www.franke.com](http://www.franke.com)

# Stainless Steel Bowls



MYTHOS



500

10 YEARS WARRANTY



Dimension: **440x450x200mm**  
Installation: **Flushmount/Slimtop/Undermount**  
Bowl Size: **400x410x200mm**

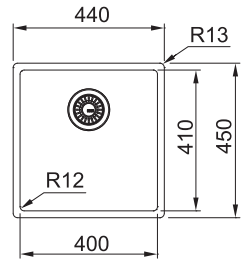
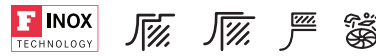

**BXM 210/110-40**

**Anthracite**  
127.0650.362

MYTHOS



600

10 YEARS WARRANTY



Dimension: **540x450x 200mm**  
Installation: **Flushmount/Slimtop/Undermount**  
Bowl Size: **500x410x200mm**

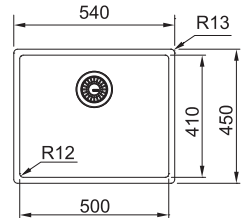

**BXM 210/110-50**

**Anthracite**  
127.0650.363

MYTHOS



800

10 YEARS WARRANTY



Dimension: **725x450x 200mm**  
Installation: **Flushmount/Slimtop/Undermount**  
Bowl Size: **685x410x200mm**

**Anthracite**  
+ Waste 127.0650.364

**Copper**  
+ Waste 127.0662.644

**Gold**  
+ Waste 127.0662.643

**BXM 210/110-68**

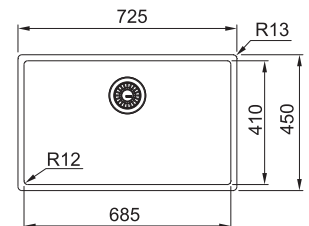
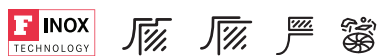

MYTHOS



800

10 YEARS WARRANTY



Our Mythos Masterpiece Premium Pack includes the BXM 210/110-68 Anthracite bowl, the compatible Chopping Board, and the dedicated Modular Bottom Grid. This latter accessory comes in handy for its extreme flexibility: use it as further protection or turn it into the best space-saving crockery drying surface, thanks to the included cards.

**BXM 210/110-68 Premium**

**Anthracite**  
127.0676.885



- Modular Bottom Grid with cards included
- Push knob pop-up waste
- Slim-Top, Flushmount or Undermount installation options

**Included Accessories**

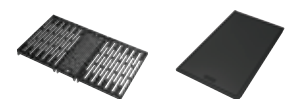

Bottom Grid Chopping Board

# Box Center



Also available in inset/flushmount models



**10**  
YEARS  
WARRANTY



Dimension: **860x510x200mm**  
 Installation: **Flushmount/Slimtop**  
 Bowl Size: **540x410x200mm/**  
**270x480x200mm**

ACCES-  
SORIES

**01 02 03 04 05 06 07**

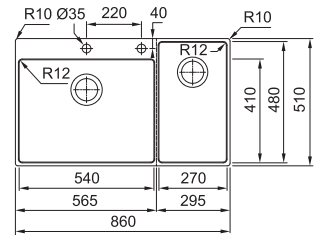

**BWX 220-54-27 TL WCR**

**Stainless Steel**  
127.0538.259

**Accessories included with Box Center BWX 220-54-27 TL WCR**

-   
**01**  
 Stainless Steel  
Strainer Bowl
-   
**02**  
 Food Preparation  
Platter
-   
**03**  
 Frame Cover
-   
**04**  
 Wire Rack
-   
**05**  
 Chopping  
Board
-   
**06**  
 Knife Holder
-   
**07**  
 Knife set



# Mythos



## Suggested Accessories

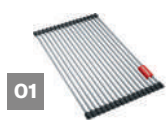

01  
Rollamat  
112.0591.081



02  
Stainless Steel  
Strainer Bowl  
112.0659.398



03  
Mobile Drainer  
112.0602.288



04  
Chopping Board  
112.0591.082

MYTHOS



Dimension: **512x412x200mm,R31**  
Installation: **Flushmount**  
Bowl Size: **500x400x200mm,R25**

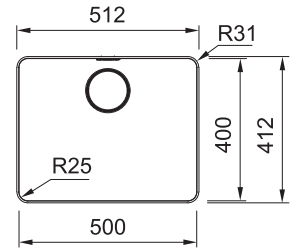

**10**  
YEARS  
WARRANTY

**MYX 210-50**

**Stainless Steel**  
127.0603.544

MYTHOS



Dimension: **740x440x 200mm,R10**  
Installation: **Undermount**  
Bowl Size: **700x400x200mm,R25**

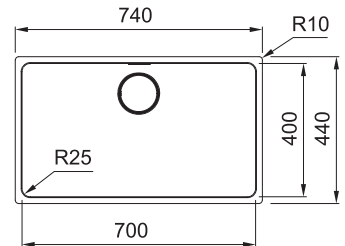
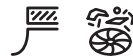

**10**  
YEARS  
WARRANTY

**MYX 110-70**

**Stainless Steel**  
122.0601.280



Dimension: **540x440x188mm,R40**  
 Installation: **Undermount**  
 Bowl Size: **500x400x 188mm, R20**

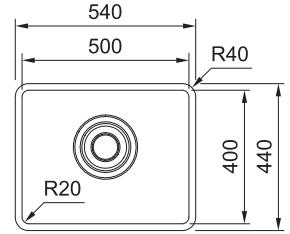

**10**  
YEARS  
WARRANTY

**MQX 110-50**

**Stainless Steel**  
122.0694.478



Dimension: **860x464x192mm, R40**  
 Installation: **Undermount**  
 Bowl Size: **820x424x192mm,R20**

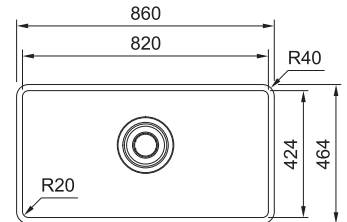
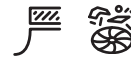

**10**  
YEARS  
WARRANTY

**MQX 110-82**

**Stainless Steel**  
122.0694.479

## The joy of precision

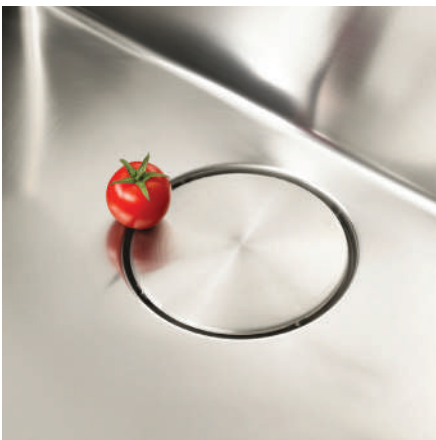

**Seamless Waste Cover**



**Unique Overflow**

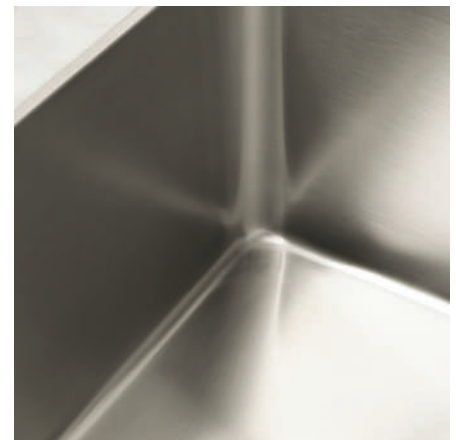

**The Perfect Rim**

MARIS



**10**  
YEARS  
WARRANTY



Dimension: **490x450x200mm,R13**  
Installation: **Flushmount/Slimtop/Undermount**  
Bowl Size: **450x410x200mmR12**

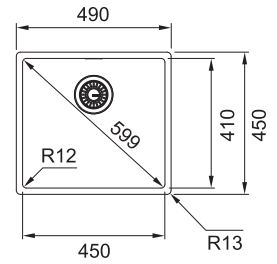

**BXX 210/110-45**

**Stainless Steel**  
127.0679.183

MARIS



**10**  
YEARS  
WARRANTY



Dimension: **760x450x200mm,R13**  
Installation: **Flushmount/Slimtop/Undermount**  
Bowl Size: **720x410x200mm,R12**

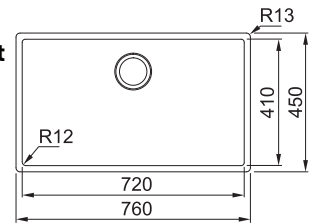

**BXX 210/110-72**

**Stainless Steel**  
127.0677.201

MARIS



**10**  
YEARS  
WARRANTY



Dimension: **782x450x200mm,R13**  
Installation: **Flushmount/Slimtop/Undermount**  
Bowl Size 1: **360x410x200mm,R12**  
Bowl Size 2: **360x410x200mm,R12**

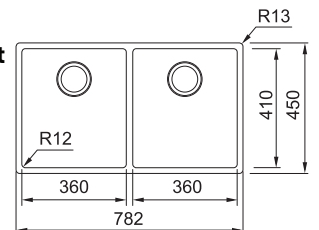

**BXX 220/120-36**

**Stainless Steel**  
127.0678.791

SMART



Dimension: **410x445x200mm,R65**  
Installation: **Undermount**  
Bowl Size: **380x415x200mm,R50**

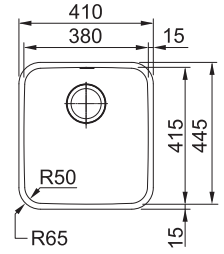

**10**  
YEARS  
WARRANTY

**BCX 110-45**

**Stainless Steel**  
122.0469.278

SMART



Dimension: **790x480x200mm,R25**  
Installation: **Undermount**  
Bowl Size 1: **380x415x200mm,R50**  
Bowl Size 2: **320x350x200mm,R50**

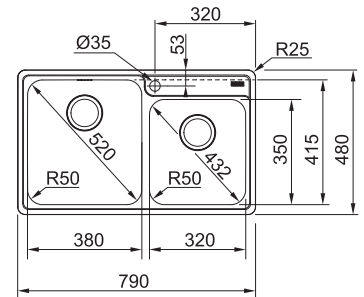

**10**  
YEARS  
WARRANTY

**BCX 620-38/32**

**Stainless Steel**  
101.0460.105

### Suggested Accessories

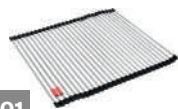

**01**

**Rollamat**  
112.0080.355



**02**

**ACC Wire Basket**  
112.0561.410



**03**

**Wooden Chopping Board (Box sinks)**  
112.0480.098



**04**

**Wooden Chopping Board**  
112.0462.252

# Fragranite Bowls



MYTHOS



10 YEARS WARRANTY



KNG 110-62

Dimension: **760x460x200mm,R10**  
Installation: **Undermount**  
Bowl Size: **620x420x200mm,R10**



**Matte black**  
125.0630.925

**Stone grey**  
125.0529.855

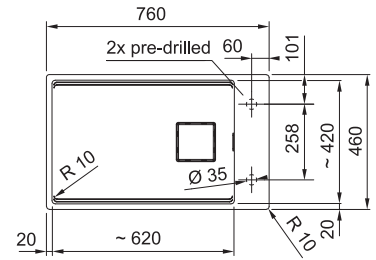

MYTHOS



10 YEARS WARRANTY



KNG 120 SG

Dimension: **760x460x200mm,R10**  
Installation: **Undermount**  
Bowl Size: **464x420x200mm,R10/**  
**214x420x200mm,R10**



**Slate grey**  
125.0714.199

**Stone grey**  
125.0529.875

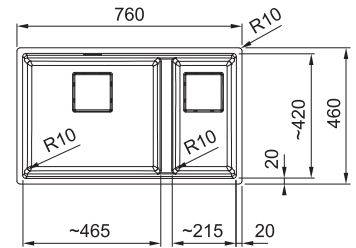

MARIS



Dimension: **560x440x200mm,R15**  
Installation: **Inset**  
Bowl Size: **520x400x200mm,R20**

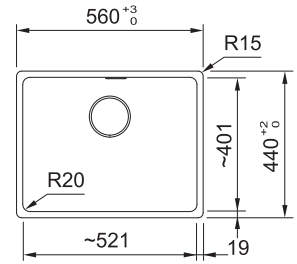

**10**  
YEARS  
WARRANTY

**MRG 610-52 ST**

**Stone grey**  
114.0661.660

MARIS



Dimension: **760x440x200mm,R15**  
Installation: **Inset**  
Bowl Size: **720x400x200mm,R20**

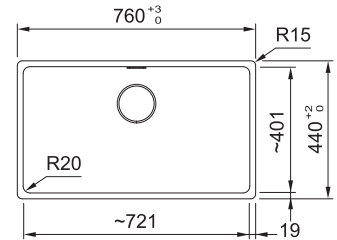
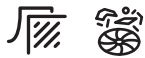

**10**  
YEARS  
WARRANTY

**MRG 610-72 ON**

**Onyx**  
114.0661.651

MARIS



Dimension: **760x510x200mm,R15**  
Installation: **Inset**  
Bowl Size: **346x400x200mm,R20/346x400x200,R20**

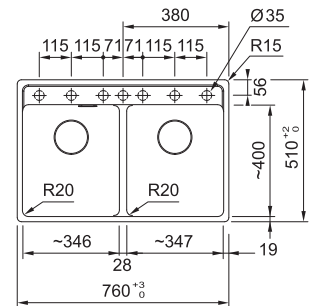

**10**  
YEARS  
WARRANTY

**MRG 620-35-35 TL ON**

**Onyx**  
114.0661.675

MARIS



Dimension: **760x440x200mm,R15**  
Installation: **Inset**  
Bowl Size: **346x401x200mm,R20/346x401x200,R20**

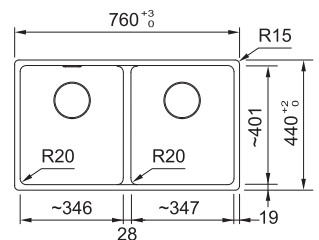
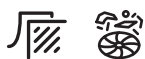

**10**  
YEARS  
WARRANTY

**MRG 620-35-35**

**Onyx**  
114.0661.683

# Taps



# Icon Taps

MYTHOS



**Icon Semi-Pro**   
 Tap Height **456mm**  
 Spout Reach **225mm**  
 Base Diameter **48mm**  
 Suitable for Low Pressure **No**  
 Tap cut-out Diameter **35mm**  
 Pull-Out Nozzle **No**  
 Pull-Out Spray **Yes**  
 Perlator **Yes**

 **Matt Black**  
 115.0690.598

**2**  
 YEARS  
 WARRANTY

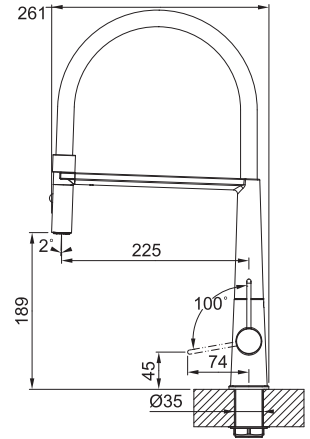

MYTHOS



**Icon Swivel Spout**   
 Tap Height **341mm**  
 Spout Reach **287mm**  
 Base Diameter **50mm**  
 Suitable for Low Pressure **No**  
 Tap cut-out Diameter **35mm**  
 Pull-Out Nozzle **No**  
 Pull-Out Spray **Yes**  
 Perlator **Yes**

 **Matt Black**  
 115.0625.187

 **Chrome**  
 115.0625.185

**2**  
 YEARS  
 WARRANTY

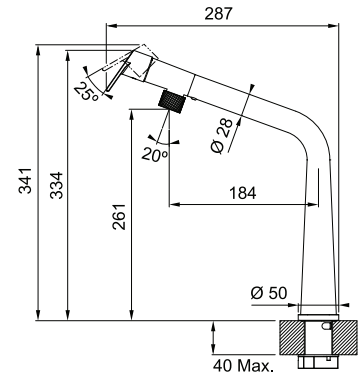

# Pescara XL Semi-Pro Taps

MYTHOS



**Pescara XL, semi-pro Pull Out Spray**   
**CT194S**  
 Tap Height **558mm**  
 Spout Reach **235mm**  
 Base Diameter **45mm**  
 Tap cut-out Diameter **35mm**  
 Water Supply Hose Length **450mm**  
 Pressure **High**  
 Aerator **Honeycomb**

 **Stainless Steel**  
 115.0472.959

**2**  
 YEARS  
 WARRANTY

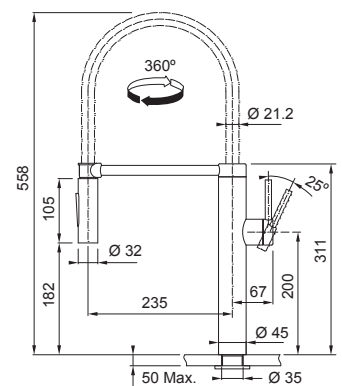

# Eos Neo Taps

MARIS



**2**  
YEARS  
WARRANTY

## Eos Neo Pull Out Spray Side CT136S

Tap Height **433mm**  
Spout Reach **231mm**  
Water Supply Hose Length **450mm**  
Tap Hole Diameter **35mm**  
Pressure **High**  
Aerator **Laminar**

 **Stainless Steel**  
115.0684.985

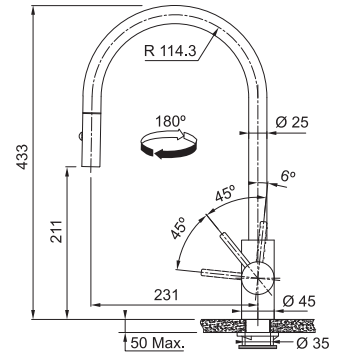

MARIS



**2**  
YEARS  
WARRANTY

## Eos Neo Pull Out Nozzle Side CT1910S

Tap Height **433mm**  
Spout Reach **230mm**  
Water Supply Hose Length **450mm**  
Tap Hole Diameter **35mm**  
Pressure **High**  
Aerator **Laminar**

 **Stainless Steel**  
115.0684.986

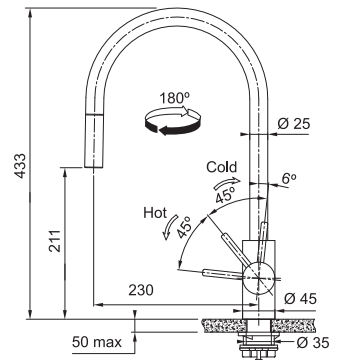

MARIS



**2**  
YEARS  
WARRANTY

## Eos Neo Swivel Side CT107S

Tap Height **387mm**  
Spout Reach **229mm**  
Water Supply Hose Length **450mm**  
Tap Hole Diameter **35mm**  
Pressure **High**  
Aerator **Laminar**

 **Stainless Steel**  
115.0684.984

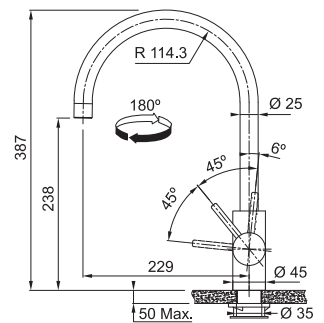

# Eos Neo Taps

MARIS



**2**  
YEARS  
WARRANTY



## Eos Neo Pull-Down Spray



Tap Height **433mm**  
 Spout Reach **231mm**  
 Water Supply Hose Length **450mm**  
 Base Diameter **45mm**  
 Tap cut-out Diameter **35mm**  
 Pressure **High**  
 Pull-Down Spray **Yes**  
 Aerator **Laminar**



**Gold**  
115.0681.244

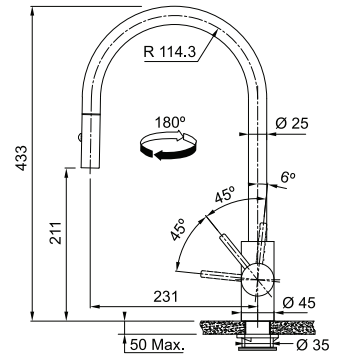

# Maris Slim L Taps

MARIS



**2**  
YEARS  
WARRANTY



## Maris Slim L-spout pull out



Tap Height **317mm**  
 Spout Reach **218mm**  
 Tap rotation **360°**  
 Water Supply Hose Length **450mm**  
 Pressure **High**  
 Aerator **Laminar**



**Matte Black**  
115.0728.394

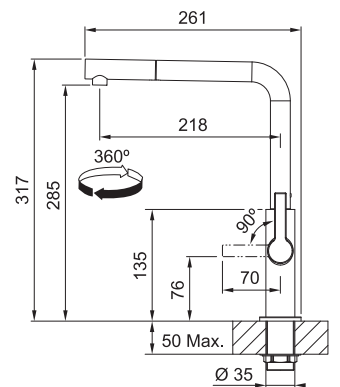

# Atlas Neo Taps

MARIS



## Atlas Neo Spray Side CT196S

Tap Height **299mm**  
 Spout Reach **235mm**  
 Tap rotation **180°**  
 Water Supply Hose Length **450mm**  
 Pressure **High**  
 Aerator **Laminar**

**Stainless Steel**  
 115.0560.513

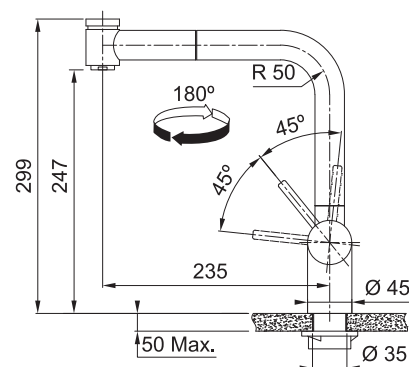

**2 YEARS**  
 WARRANTY

MARIS



## Atlas Neo pull out Nozzle side CT1310S

Tap Height **297mm**  
 Spout Reach **225mm**  
 Tap rotation **180°**  
 Water Supply Hose Length **450mm**  
 Pressure **High**  
 Aerator **Laminar**

**Stainless Steel**  
 115.0560.512

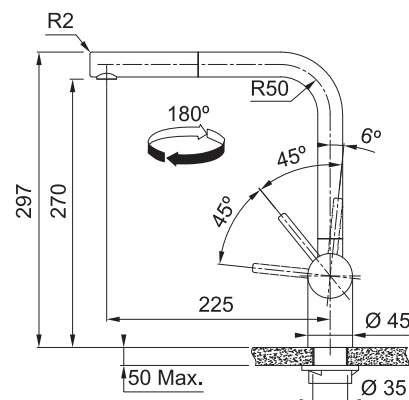

**2 YEARS**  
 WARRANTY

MARIS



## Atlas Neo pull out

Tap Height **297mm**  
 Spout Reach **225mm**  
 Base Diameter **45mm**  
 Tap cut-out Diameter **35mm**  
 Suitable for Low Pressure **No**  
 Aerator **Laminar**

**Anthracite**  
 115.0667.608

**Copper**  
 115.0667.606

**Gold**  
 115.0667.607

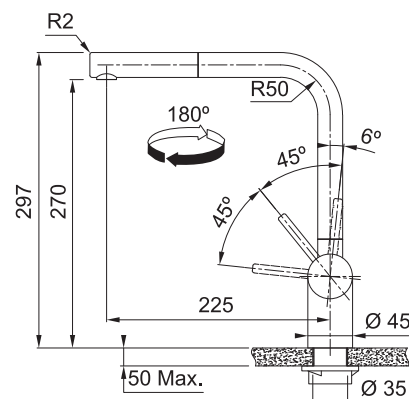

**2 YEARS**  
 WARRANTY

# Lina Taps

SMART



## Lina L pullout nozzle

**CT935C**

Tap Height **285mm**

Spout Reach **218mm**

Tap rotation **360°**

Water Supply Hose Length **450mm**

Pressure **High**

Aerator **Honeycomb**

**2**  
YEARS  
WARRANTY

 **Chrome**  
115.0703.326

 **Stone Grey**  
115.0728.486

 **Onyx**  
115.0728.484

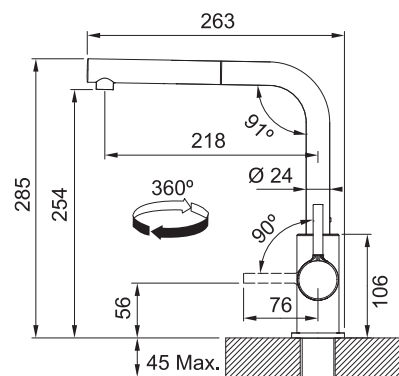

# Semi-Pro Taps

SMART



## Lina Semi Pro Dual Side

**CT 995C**

Tap Height **410mm**

Spout Reach **205**

Tap operation **360°**

Water Supply Hose Length **450mm**

Pressure **High**

Aerator **Honeycomb**

**2**  
YEARS  
WARRANTY

 **Chrome**  
115.0635.332

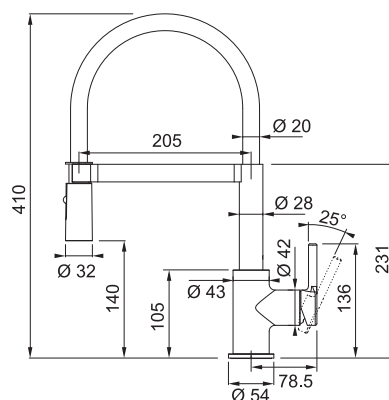



# Hob Extractors

MYTHOS



83



**2**  
YEARS

WARRANTY

Black  
FMY 839 HI 2.0  
340.0652.100



**Hood Features**

Installation type  
Version

Energy class  
Extraction speeds  
Controls  
Charcoal Filter

**Hob Extractor**  
**Recirculating and ducted extraction**  
**A+++**  
**8 + 2 intensive levels**  
**Capacitive Touch**  
**Not Included**

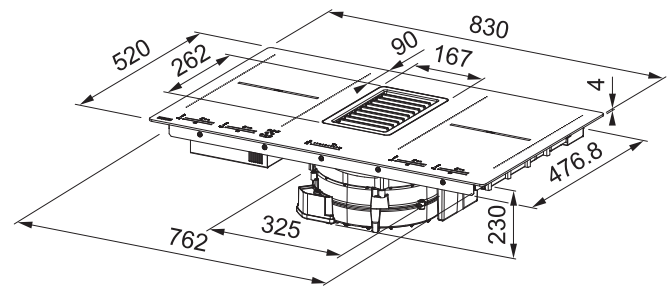

Speed	Min	Max	Intensive 1	Intensive 2
Air capacity (m³/h)	245	505	700	550
Input	35	125	220	140
Noise level (dB)	51	65	72	66

**Temperature Management**

- ⎓ Melting 42°C
- ⎓⎓ Keep Warm 74°C
- ⎓⎓⎓ Slow Cooking 92°C

**Induction Hob Features**

Dimensions: **830x520mm**  
Cut out: **832x522mm**  
Number of zones: **4**  
Digit colour: **White**  
Control: **Flex touch sliders**  
Special Functions: **Thawing, Keeping Warm, Melting, Stop & Go, Power Management, Flexi Zone, progressive adjustment from 1 to 9 + Booster for each cooking zone**  
Power: **4x 220x180 2100W, Booster : 3700W**  
Timer: **End of cooking timer for each zone**  
Total power: **consumption 7.4 kW**  
**Child safety**  
Note: **Installation slim-top/flush-mount**

Note: For the installation of the Mythos 2gether, you must purchase the following kits



H6 Recirculating Kit  
112.0539.568

H6 Refill Ceramic Filter  
112.0548.447

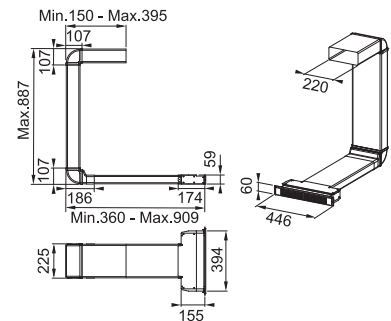

# Smart 2gether



SMART

70



**2**  
YEARS  
WARRANTY

Black  
FSM 709 HI  
340.0678.203



**Hood Features**

Installation type  
Version

Energy class  
Extraction speeds  
Controls  
Charcoal Filter

**Hob Extractor**  
**Recirculating and ducted extraction**  
**A++**  
**9+ intensive level**  
**Capacitive Touch**  
**Not Included**

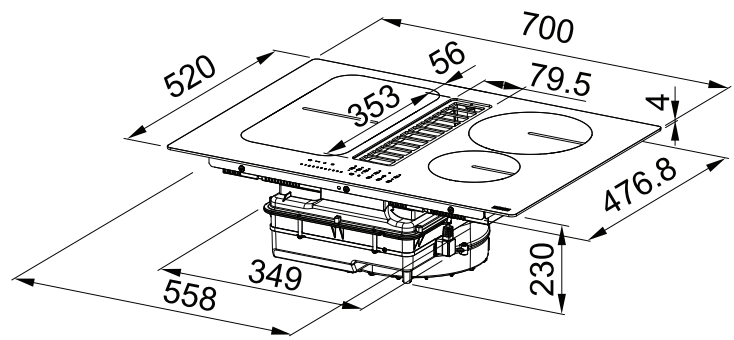

Speed	Min	Max	Intensive 1	Intensive 2
Air capacity (m³/h)	230	350	500	630
Input	40	75	125	220
Noise level (dB)	49	57	65	71

**Induction Hob Features**

Dimensions: **700x520mm**  
 Cut out: **See template**  
 Number of zones: **4**  
 Digit colour: **Red**  
 Control: **Touch buttons and one slider**  
 Special Functions: **4 induction zones, 9 levels + booster function, stop & go, power management, bridge, flexi zone.**  
 Power: **4x 220x180 2100W, Booster : 3700W**  
 Timer: **End of cooking timer for each zone**  
 Total power: **consumption 7.4 kW**  
**Child safety**  
 Note: **Installation slim-top/flush-mount**

# Hoods



MYTHOS



**2**  
YEARS

WARRANTY

Black  
FC988NX  
330.0720.124



**Hood Features**

- Installation type
- Version
- Material
- Extraction speeds
- Controls
- Connection
- Overall dimension:

- Wall-mount
- Recirculating and ducted extraction
- Tempered Glass Black & Stainless Steel
- 3
- Gesture Control
- K-Link
- 896 x 416 x 1,068-1346mm

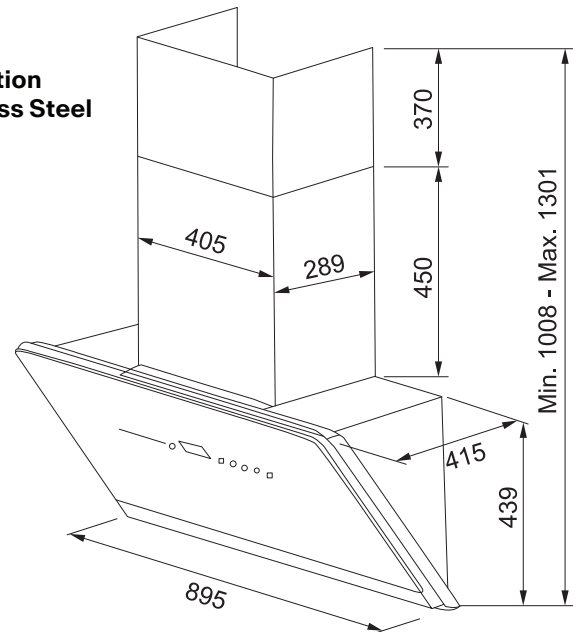

MARIS



3±



**2**  
YEARS  
WARRANTY

Black  
FBFE BK MATT A70  
305.0665.365



**Hood Features Box Flush Evo 70cm**

Installation type  
Version

Hood category  
Energy class  
Extraction speeds  
Controls  
Remote control  
Charcoal Filter  
Lighting

Cabinet  
Recirculating and  
ducted extraction  
Built-in  
B  
3+i  
Push Button  
No  
No  
LED Bar

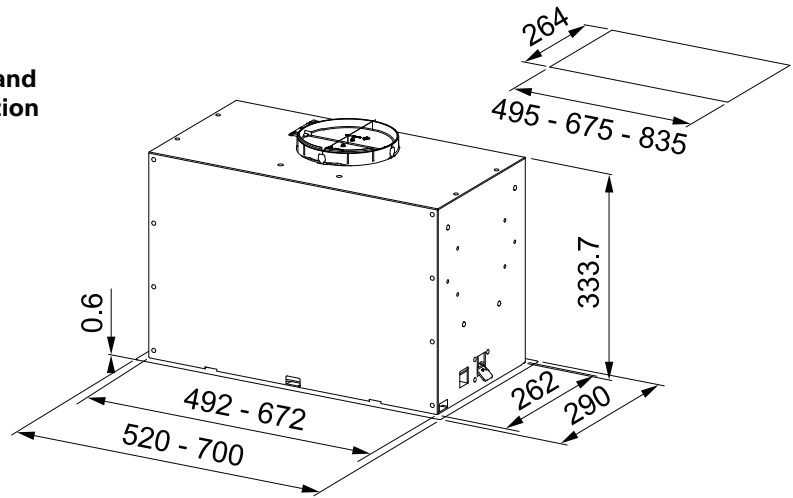

Speed	Min	Max	Intensive
Air capacity (m <sup>3</sup> /h)	280	570	670
Input W	130	210	250
Noise level (dB)	47	63	66

SMART



3



**2**  
YEARS  
WARRANTY

Black  
FSMD 508 BK  
335.0528.006



**Hood Features**

Installation type  
Version

Rear venting  
Energy class  
Extraction speeds  
Controls  
Remote control  
Charcoal Filter  
Lighting

Wall  
Recirculating and  
ducted extraction  
Yes  
A  
3  
UI  
No  
Yes  
LED Bar Slim



Speed	Min	Max	Intensive
Air capacity (m³/h)	270	370	630
Input W	150	200	250
Noise level (dB)	47	54	65

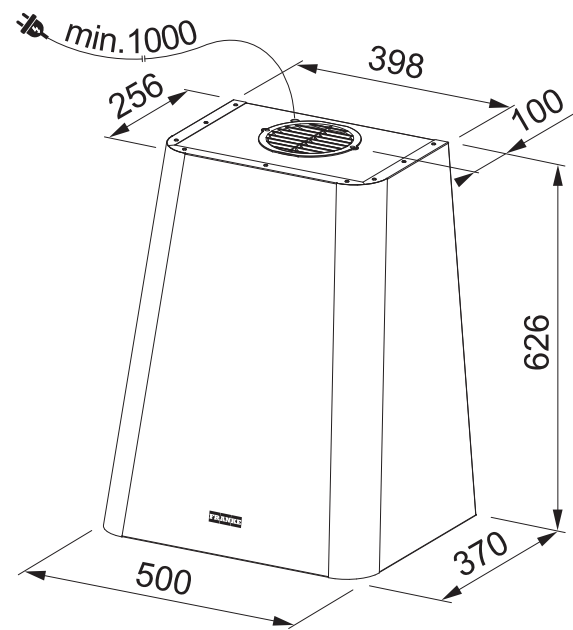

SMART



42

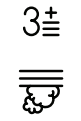

2 YEARS WARRANTY

Black  
FSMS 42 BK MATT  
345.0654.933



**Hood Features**

- Installation type
- Version
- Rear venting
- Energy class
- Extraction speeds
- Controls
- Remote control
- Charcoal Filter
- Lighting

- Island
- Recirculating
- No
- A
- 3+i
- Push Button
- No
- Yes
- 2 x LED



Speed	Min	Max	Intensive
Air capacity (m³/h)	270	580	740
Input	150	240	250
Noise level (dB)	53	66	70

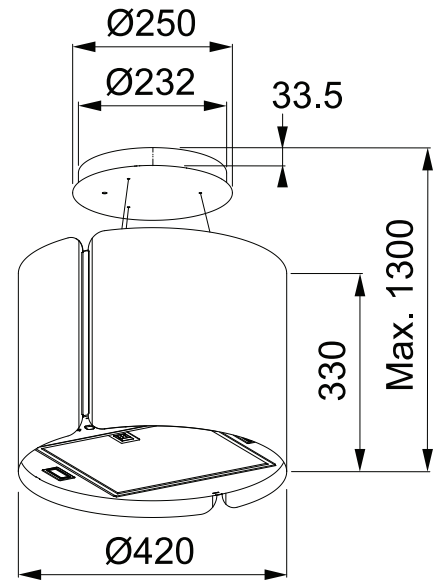

90

3



**2**  
YEARS

WARRANTY

Stainless Steel  
FPG 905 SA  
315.0575.883

### Hood Features

Installation type  
Version

Extraction speeds

Controls

Material

Overall dimension

**Cabinet-mounted  
Recirculating and  
ducted extraction**

**3**

**Touch control**

**Black Glass & Stainless Steel**

**900/600 x 300-450 x 280mm**

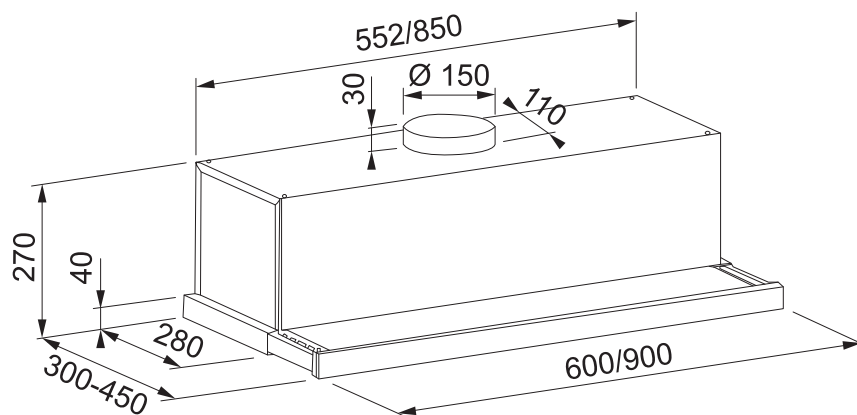

# Downdraft



The motorised Downdraft hood allows for an unobtrusive, subtle kitchen style. The motor is situated in the cabinet underneath the hob which can be vented externally, or in recirculating mode. The motor can be installed at the front or rear according to the position of the kitchen unit. Compatible with gas, electric and induction hobs.



**2**  
YEARS  
WARRANTY

Black  
FDW 908 IB XS  
110.0365.588



**Hood Features**

- Installation type
- Version
- Rear venting
- Energy class
- Extraction speeds
- Controls
- Remote control
- Charcoal Filter
- Lighting

- Worktop**
- Recirculating and ducted extraction**
- N/A**
- A**
- 4 + Boost**
- Capacitive Touch**
- Can be purchased separately**
- Not Included**
- LED Bar**



Speed	1	2	3	4	BOOST
Air capacity (m <sup>3</sup> /h)	200	280	350	440	720
Press. Max (PA)	100	390	490	550	560
Power (Watt)	45	100	135	170	250
Noise level (dB)	43	49	53	57	68

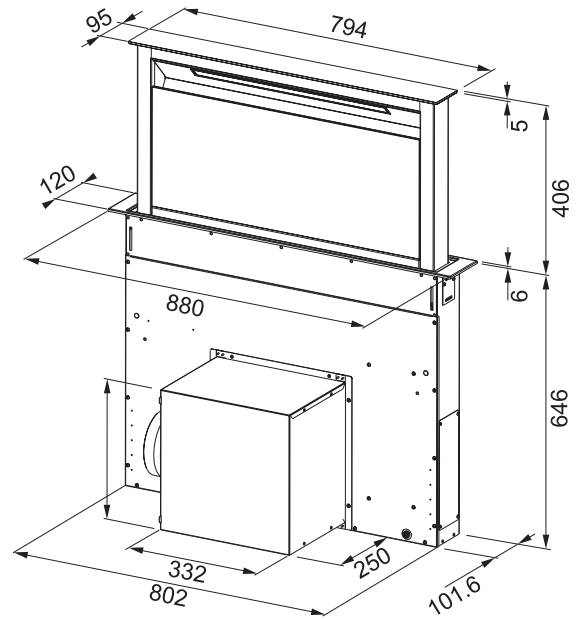

REMOTE CONTROL  
OPTIONAL



# Ovens



MYTHOS



**2**  
YEARS  
WARRANTY

Black  
FMY 99 HS BK  
116.0613.707

Type: **Multifunction**  
Energy efficiency class: **A+**  
Maximum cavity capacity: **73 lt**  
Control panel: **Display is TFT full touch in colours**  
Number of functions: **19**  
Cookassist: **60**  
Special functions: **15**  
Door: **Smooth2close**  
Inner door: **Full glass**  
Guides: **1 telescopic guide**  
Equipment: **2 grids, 1 tray, 1 steam tray, 1 deep tray**  
Notes: **Steam cleaning system**

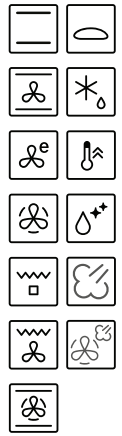

MYTHOS



**2**  
YEARS  
WARRANTY

Black  
FMY 99 P BK  
116.0613.709

Type: **Multifunction**  
Energy efficiency class: **A+**  
Maximum cavity capacity: **73 lt**  
Control panel: **Display is TFT full touch in colours**  
Number of functions: **10**  
Cookassist: **42**  
Functions: **17**  
Special functions: **15**  
Door: **Smooth2close**  
Inner door: **Full glass**  
Guides: **1 telescopic guide**  
Equipment: **2 grids, 1 tray, 1 deep tray**  
Notes: **Pyrolytic self-cleaning system**

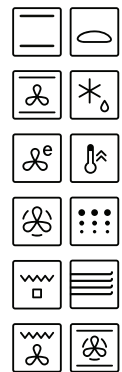

MYTHOS



**2**  
YEARS  
WARRANTY

Black  
FMY 98 P BK  
116.0606.102

Type: **Multifunction**  
Energy efficiency class: **A+**  
Maximum cavity capacity: **73 lt**  
Control panel: **white LCD display and push-pull knobs**  
Number of functions: **10**  
Cookassist: **9**  
Door: **Smooth2close**  
Inner door: **Full glass**  
Guides: **1 telescopic guide**  
Equipment: **2 grids, 1 tray, 1 deep tray**  
Notes: **Pyrolytic self-cleaning system**

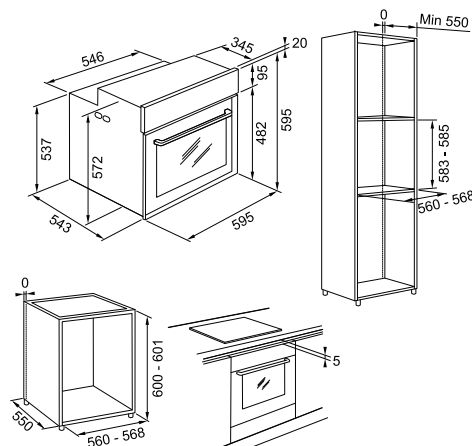
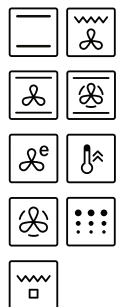

**2**  
YEARS

WARRANTY

Inox  
FMA 97 P XS  
116.0606.100

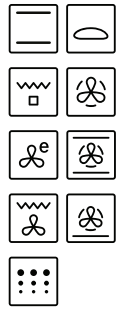

Type: **Multifunction**  
 Energy efficiency class: **A+**  
 Maximum cavity capacity: **71 lt**  
 Control panel: **White LED display with push-pull knobs**  
 Number of functions: **9**  
 Door: **Smooth2close**  
 Inner door: **Full glass**  
 Equipment: **2 wire shelves (1 level partial), 1 baking tray, 1 deep tray**  
 Notes: **Pyrolytic self-cleaning system**

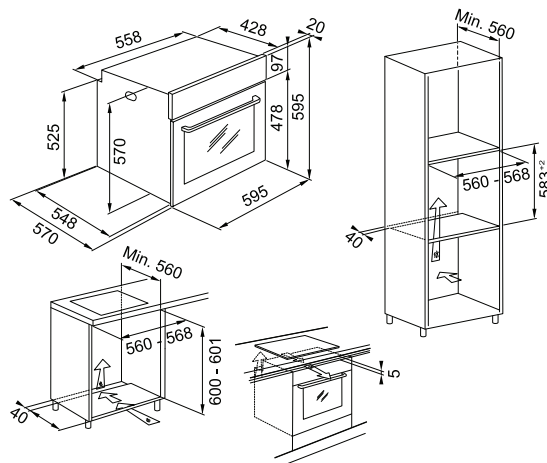

SMART

**2**  
YEARS  
WARRANTY

Inox  
FSM 97 P XS  
116.0606.096



Type: **Electric**  
Maximum cavity capacity: **71 lt**  
Energy efficiency class: **A+**  
Control panel: **Protruding Knobs with White LED Display**  
Number of functions: **9**  
Automatic: **2 Automatic cooking functions**  
Door: **Smooth2close**  
Guides: **1 level of telescopic guides**  
Equipment: **Grill grid, baking tray, deep tray**  
Notes: **Pyrolytic cleaning system**

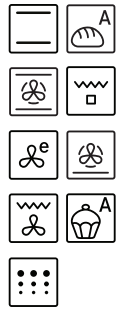

SMART

**2**  
YEARS  
WARRANTY

Inox  
FSM 86 H XS  
116.0605.990



Type: **Electric**  
Maximum cavity capacity: **71 lt**  
Energy Efficiency Class: **A**  
Control panel: **Protruding Knobs**  
Display: **White LED**  
Functions: **8**  
Door: **Smooth2Close**  
Guides: **Optional telescopic guides**  
Equipment: **2 grids, 1 baking tray, 1 deep tray**

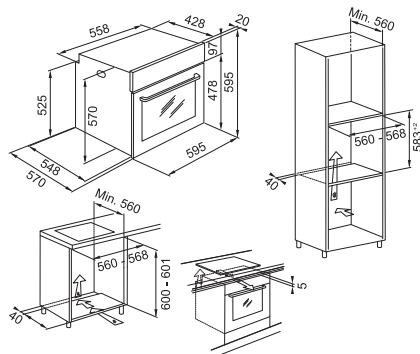
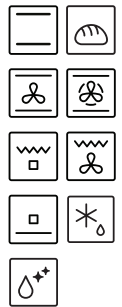

**2**  
YEARS  
WARRANTY

Black  
FBO 6200 BXP  
116.0679.486



Type: **Electric**  
Maximum cavity capacity: **60 lt**  
Control panel: **Touch screen panel**  
Display: **White LED**  
Number of functions: **10**  
Automatic: **3 Automatic cooking menus**  
Door: **Soft close hinges and easy removable oven door**  
Guides: **Telescopic guides**  
Equipment: **Universal tray, baking rack, roasting rack, roasting support rack, tray holder, food clip**

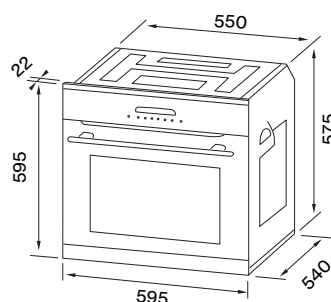
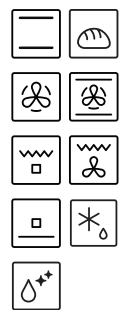

# Microwaves



MYTHOS



**2**  
YEARS  
WARRANTY

Black  
FMY 45 MW BK  
131.0632.660



Type: **Combi Microwave**  
Maximum cavity capacity: **40 lt**  
Control panel: **Push-Pull Knobs with LCD Display**  
Number of functions: **9**  
Cookassist: **10**  
Functions: **9**  
Special functions: **7**  
Door: **Smooth2close**  
Inner door: **Full glass**  
Guides: **N/A**  
Equipment: **Glass turn table, grill grid, steam box container, baking tray, cover plate**

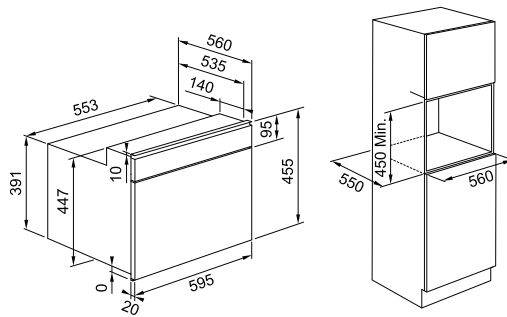
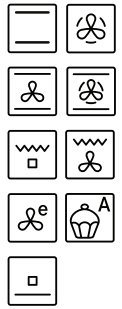

# Warming Drawer

MYTHOS



**2**  
YEARS  
WARRANTY

Black  
FMY 14 P DRW BK  
131.0640.710



Cavity Capacity: **16 lt**  
Load Capacity: **25kg**

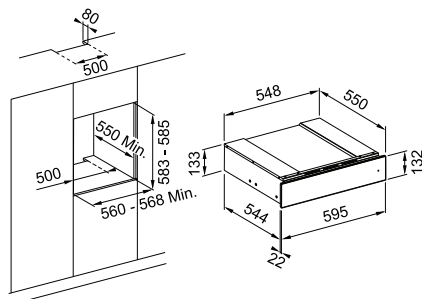

**2**  
YEARS  
WARRANTY

Inox  
FMA 45 MW XS  
131.0606.104



Type: **Combi Microwave**  
 Maximum cavity capacity: **40 lt**  
 Control panel: **LED white display with push-pull knobs**  
 Number of functions: **7**  
 Door: **Smooth2close**  
 Inner door: **Full glass**  
 Equipment: **360° Glass turntable, 1 wire shelf, 1 baking tray, 1 coverplate**

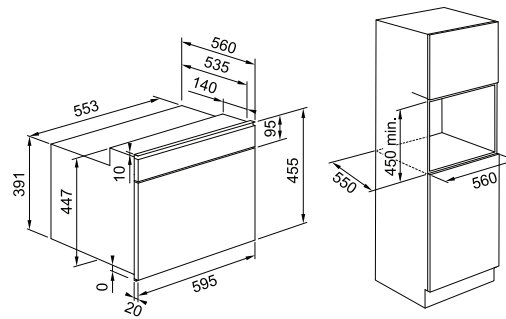

SMART



**2**  
YEARS  
WARRANTY

Inox  
FSM 45 MW XS  
131.0606.103



Type: **Combi Microwave**  
Maximum cavity capacity: **40 lt**  
Control panel: **Push-Pull Knobs with White LCD Display**  
Number of functions: **8**  
Automatic recipes: **5**  
Door: **Smooth2close**  
Equipment: **Grids, dripping pan, grill grid, cover plate**

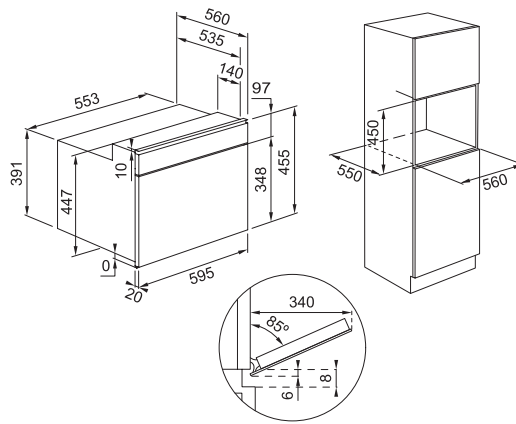

SMART



**2**  
YEARS  
WARRANTY

Inox  
FSM 25 MW XS  
131.0627.471



Type: **Electric**  
Maximum cavity capacity: **25 lt**  
Control panel: **Touch screen panel**  
Display: **White LED**  
Number of functions: **14**  
Functions: **6, plus 8 automatic cooking menus**  
Door: **Smooth2close**  
Start delay function: **Yes**  
Timer setting: **95mins**

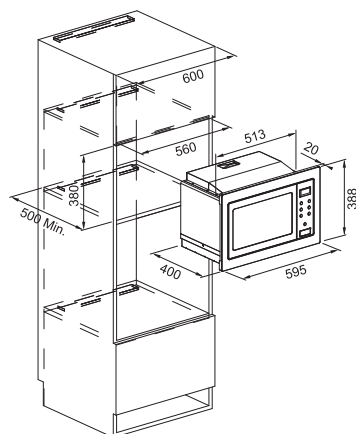

# Induction Hobs



MYTHOS



600

2 YEARS

WARRANTY

Black  
FMY 658 I FP  
108.0613.587

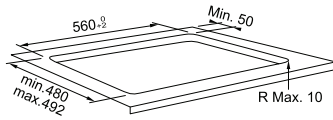
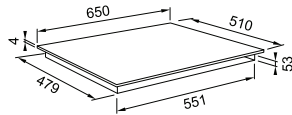

Type: **Electric**  
Technology: **Induction vitroceramic**  
Cut out: **551x479mm**  
Slider Controls: **LCD text assisted displays**  
Digit colour: **White**  
Central Controls: **LCD text assisted displays**  
Auto Cook: **Full auto cook in chef area with cooking menu**  
Cook Assist: **EasyCook, ProCook and FlexPro.**  
Special Features include: **Melting, Simmering, Boiling, Pan frying, grilling and Moka**  
Fitting: **Frameless**  
Flex Zone Areas: **1 full pro-flex**  
Total Power: **7.4kW**

MARIS



600

2 YEARS

WARRANTY

Black  
FMA 654 I F BK  
108.0606.111

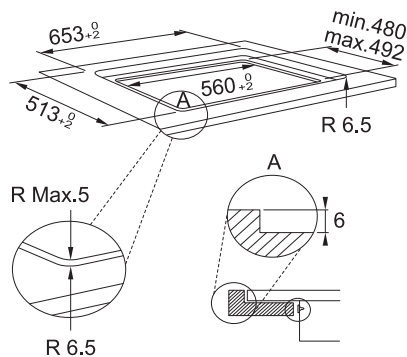
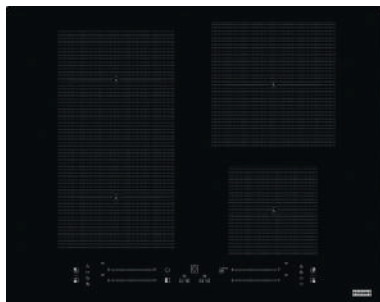

Type: **Electric**  
Technology: **Induction vitroceramic**  
Cut out: **560x480mm**  
Controls: **Sliding touch control**  
Digit colour: **Red**  
Power level : **18 + booster**  
Cooking zones: **4**  
Special Features: **Flexi zone, power adjustment + Booster, special delicate cooking functions**  
Total Power: **7.2kW**

SMART



600

2 YEARS WARRANTY



Type: **Electric**  
 Technology: **Induction**  
 Cut out: **560 x 480-492 x 90mm, R10mm**  
 Controls: **Direct touch control**  
 Digit colour: **Red**  
 Number of Heating zone: **3 - Dual**  
 Power Level: **9 + booster**  
 Cookassist: **Boiling, Melting**  
 Total Power: **7.2kW**

Black  
 FSM 653 I D BK  
 108.0606.109

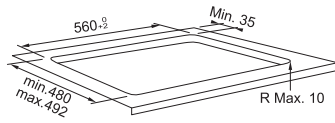
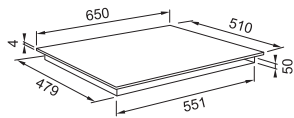

SMART



700

2 YEARS WARRANTY

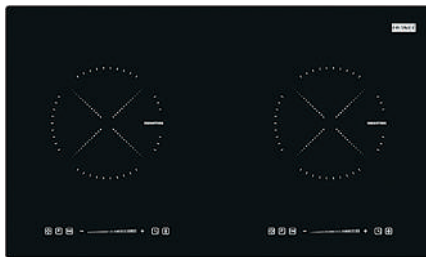

Type: **Electric**  
 Technology: **Induction**  
 Cut out: **670x400mm**  
 Controls: **Slide touch control panel**  
 Digit colour: **Red**  
 Number of Heating zone: **2**  
 Power level : **9**  
 Electronic timer: **180 min**  
 Total Power: **3.4kW**

Black  
 FIH 7210  
 108.0537.204

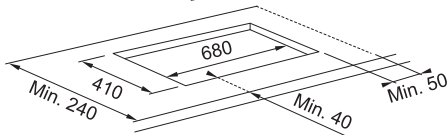
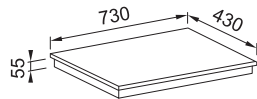

SMART

600

2  
YEARS  
WARRANTY

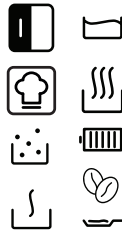

Type: **Electric**  
 Technology: **Induction**  
 Cut out: **560x490mm**  
 Controls: **Direct sensor touch control panel**  
 Digit colour: **Red**  
 Number of Heating zone: **3**  
 Power level: **9**  
 Electronic timer: **99 min**  
 Total Power: **7.2kW**

Black  
 FIH 6310  
 108.0636.342

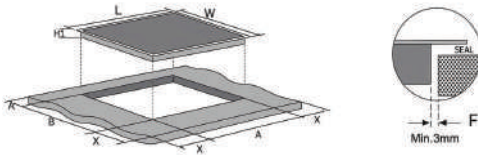

L(mm)	W(mm)	H(mm)	D(mm)	A(mm)	B(mm)	X(mm)	F(mm)
590	520	62	58	560+4 +1	490+4 +1	50min	3min

SMART

300

2  
YEARS  
WARRANTY



Type: **Electric**  
 Technology: **Induction**  
 Cut out: **268x500mm**  
 Slider Controls: **Yes**  
 Digit colour: **Red**  
 Number of Heating zone: **2**  
 Power level: **9**  
 Electronic timer: **99 min**  
 Total Power: **3.5kW**

Onyx  
 FIH 3210  
 108.0635.101

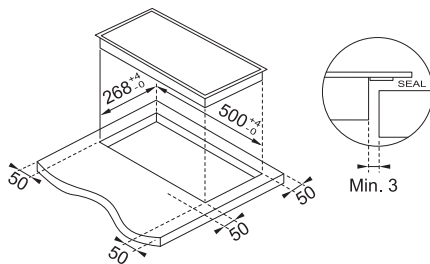

A (mm)	B (mm)	C (mm)	D (mm)	E (mm)	F (mm)	G
268+4 -0	500+4 -0	50min.	50min.	50min.	50min.	3mm min.

# Dishwashers



## Dishwasher FDW 614 D10P DOS LP C

MYTHOS

**2**  
YEARS  
WARRANTY



FUN Number: 117.0611.675

- Width: 60cm
- Energy Efficiency Class: C
- C/A/A(energy, cleaning, drying)
- Electronic programmer with digital display
- 14 Place settings
- 10 Washing Programs - Eco, Auto, Intensive, Quick wash and dry, Crystals, Quick 30', Silent, Pre-wash, Antibacterial, Self-cleaning
- 1-12h delay
- Half Load Washing
- Electronic Aqua Stop
- Automatic Door Opening at the end of the cycle (Door Opening System)
- Cutlery 3rd basket
- Exterior Dimensions (W x H x D): 598 x 820 x 555mm

## Dishwasher FDW 614 E5P E

SMART

**2**  
YEARS  
WARRANTY



FUN Number: 117.0694.396

- Width: 60cm
- Energy Efficiency Class: E
- E/A/A(energy, cleaning, drying)
- Electronic programmer with digital display
- 14 Place settings
- 5 Washing Programs - Eco, Intensive, Mixed, Rapid 28', Fast Wash & Dry
- Electronic salt indicator
- Exterior Dimensions (W x H x D): 598 x 820 x 555mm

## Dishwasher FDW 4510 E8P E

SMART

**2**  
YEARS  
WARRANTY



FUN Number: 117.0616.305

- Width: 45cm
- Energy Efficiency Class: E
- Capacity: 10 place settings
- Electronic programmer with digital display
- 14 Place settings
- 8 Washing Programs - Eco, Intensive, Normal, Glass, Rapid, 90', 60', Pre-wash
- Electronic salt indicator
- Exterior Dimensions (W x H x D): 448 x 820 x 555 mm

# Refrigerator



# Refrigerator FCB 320 V NE D

MARIS

**2**  
YEARS  
WARRANTY

**FAST**  
❄️

**EASY**  
❄️



177 cm  
SUPER ALTO



60 cm  
SUPER WIDE

**FUN Number:** 118.0722.592

- Capacity: 273 lt
- Double door (Refrigerator with freezer)
- Maximum energy efficiency and great comfort of use for a range of high performance refrigerators
- The LED light guarantees excellent visibility, low consumption, long life
- Height-adjustable glass shelves
- Direct cooling fan technology
- Reversible doors
- 3 Shelves, 1 Drawer, 3 Freezer Drawers
- 1 bottle holder, 1x6 egg containers
- Color: White

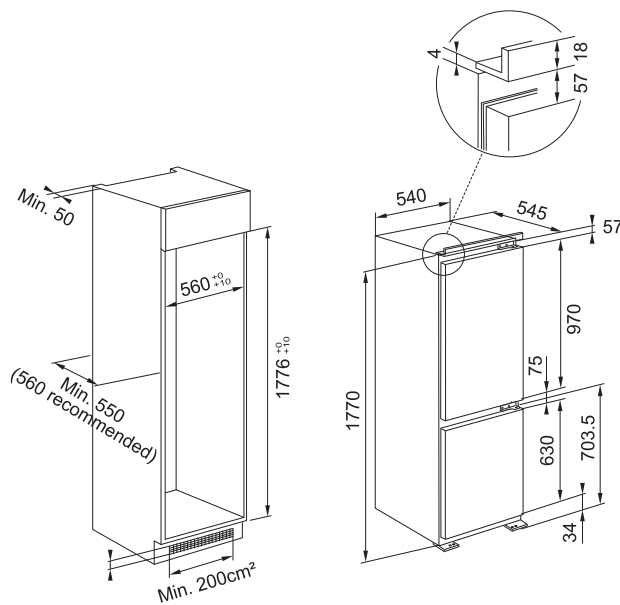

# Wine Cooler



The ideal storing environment for your wine collection which integrates into the beauty of your own kitchen. The optimal conditions usually exclusively guaranteed by an underground cellar are now akin of those our Mythos Wine Cooler can provide, with the noticeable advantage of offering you the chance to have up to 24 of your favourite bottles always at hand.

## A Wine Cooler like no other

The Mythos Wine Cooler temperature can be set from 4° to 18°, ensuring your wine collection is maintained to perfection. Keeping the characteristics of your wine intact, the Anti-UV glass filters enough light through to ensure optimal preservation. The electronic display allows the temperature to be visible at all times and the LED light perfectly highlights every detail, while the 3 sliding premium oak built-in shelves bring elegance to your wine collection.

MYTHOS



2 YEARS

WARRANTY

Mythos Wine Cooler  
FMY 24 WCR N BK  
131.0717.412



**Features:**

- 24 bottle capacity
- Push-Push lateral door opening
- 3 sliding shelves
- Shelves in oak wood
- Temperature range: 4°C - 18°C
- Internal electronic display
- LED light
- Anti-UV glass for optimal wine preservation
- Cut-out Dimensions (W x H x D): 560 x 450 x 560mm

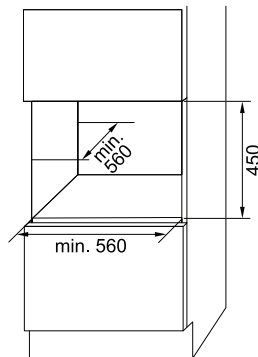

# Accessory Drawer

MYTHOS



2 YEARS

WARRANTY

Mythos Wine Cooler Accessory Drawer  
FMY 14 WCRD BK  
131.0694.161

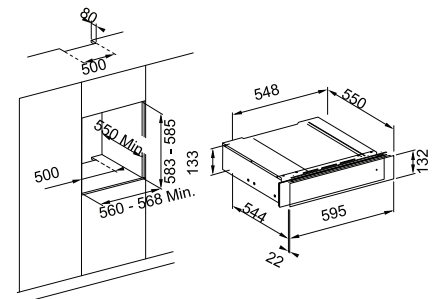

1. Blade corkscrew
2. Foil cutter
3. Wing corkscrew
4. Sommelier corkscrew
5. Wine drip ring
6. Champagne bottle cap
7. Wine pourer cap
8. Wine aerator pourer
9. Champagne opener

Wine Accessories Kit



www.franke.com 73

# Coffee Machine



MYTHOS



2 YEARS WARRANTY

WARRANTY

Mythos Coffee Machine  
FMY 45 CM BK  
131.0682.091



**Features:**

Electronic Touch, White display  
Capacity of Water Tank: 1.8 Litres  
Capacity of Coffee Beans drawer: 200g  
N° of cup: 1 or 2

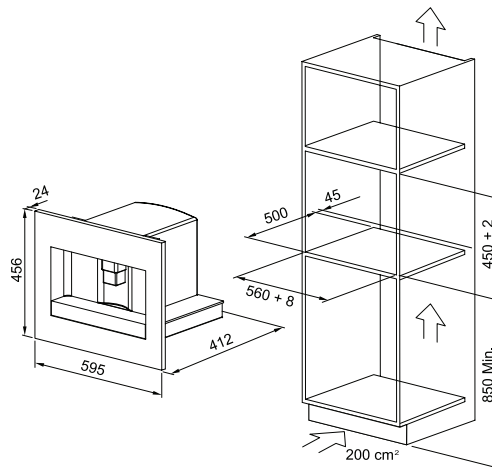

# Accessory Drawer

MYTHOS



2 YEARS WARRANTY

WARRANTY

Mythos Coffee Machine Accessory Drawer  
FMY CMD BK  
131.0694.163

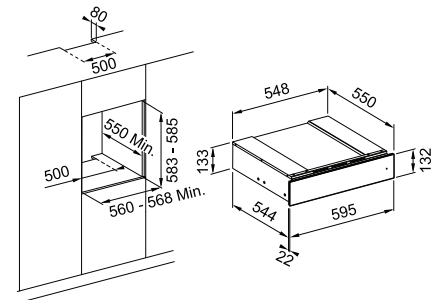

Coffee Accessories Kit



1. Coffee beans holders



2. Tea/infusers leaves holders



3. Latte art set



4. Infuser



5. Spoon



6. Additional space to hold sugar/tea bags etc

# Elite Slimline Food Waste Disposer

Cook like a chef, grind like a master



## SLIM 75

3/4 HP Disposer  
134.0721.252

Horsepower: 3/4 • Feed: Continuous • RPM: 2700 • Hygiene Safeguard Flange • Sound Softening Insulated Shell • Stainless Steel Grinding Chamber • Twist Force Balanced Grinding System • Jam Resistant • Cast Impellers • Antimicrobial Removable Splash Guard • 3-Bolt installation • Integrated Air Switch Connection

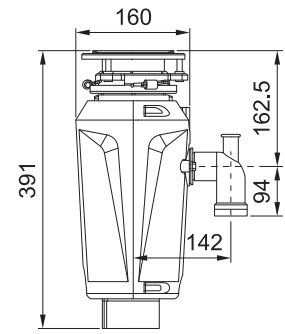

### A powerful performance

Thanks to innovative Twist Force technology that offers exceptional grinding power, you can expect fast and efficient results without jamming. A hygiene safeguard also fights against the growth of bacteria and unpleasant odours with its antimicrobial protection.

### Details that deliver

Each waste disposer features a high-flow splash guard ensuring the grinding chamber is left clean, Sound Soft Technology for noise reduction, and a strong Magnetic Rim on selected models to attract kitchen utensils and other miscellaneous metal objects.



### Elegance under the sink

Thanks to a 3-Bolt Mounting System that makes it compatible with all Franke sinks and bowls that feature a 3 1/2" waste hole, and an elegant-shelled body which is designed to save maximum space underneath the sink, each Elite Slimline Waste Disposer is a refreshing piece of Franke innovation that is a welcome addition to any kitchen.



# Clean & Care



## Overview

General maintenance is wonderfully simple increase the lifespan of your Franke products and prevent the buildup of dirt and limescale by simply wiping down your Fraganite sink, tap and all stainless steel surfaces with a damp cloth and soapy water. Discover more top cleaning tips below.



112.0530.238

### Colored Sink Cleaner (250ml)

Cleaning a colored mineral cast sink is like washing a car. In order to keep it clean you have to make sure the water drops roll off the surface without leaving lime scale deposits. This is exactly what the specialised Franke Kitchen Care Colored Sink Cleaner does. It removes dirt deposits and protects your sink effectively from water stains.



112.0530.239

### Tap Cleaner (250ml)

When looking at a shiny tap, one tends to forget all the technology and mechanics tucked inside. There are valves, cartridges, seals, and filters that might get harmed if you use an aggressive cleaner. The Franke Kitchen Care Tap Cleaner removes all lime scale and dirt gently but thoroughly, thus preserving the beauty and performance of your tap for years.



112.0530.237

### KITCHEN CARE Sink Cleaner (200ml)

A compound uniquely developed for our stainless steel surfaces and their professional cleaning and care. The paste is acid-free and the polishing compounds embedded within it provides for a sustainable and gentle cleaning.



**FRANKE**

Franke-Strasse 2  
P.O. Box 4663 Aarburg,  
Switzerland

**HTM** Homes

HTM GROUP JOINT STOCK COMPANY  
34 Phan Dinh Giot Street,  
Tan Son Hoa Ward,  
Ho Chi Minh City, Vietnam